



**MAINTENANCE MANUAL**

**SPLIT DIMMER SUPPLY**

PART NO. 080-22014-01

SERIAL NO. 3070010 AND SUBSEQUENT

*ECCN*  
*4658*  
*4771*

**ECCN**  
**9E991**

**DWG NO. 004-72000**  
**REVISION -, FEB 14, 1995**

**COPY**

**ORIGINAL**

REV	DESCRIPTION	LOG OF REVISIONS APPROVAL	DATE
-	INITIAL RELEASE	<i>M. Hamaker</i>	2/14/95

PREMIER AVIATION  
 2617 AVIATION PARKWAY  
 GRAND PRAIRIE, TEXAS 75052  
 PHN: 214-988-6181  
 FAX: 214-660-2670

**ORIGINAL**

**PREMIER AVIATION  
SPLIT DIMMER SUPPLY  
MAINTENANCE MANUAL  
DWG NO. 004-72000**

**DISCLOSURE NOTICE**

The drawings, specifications, descriptions, schematics and other technical data attached hereto are proprietary and confidential to Premier Aviation Inc. and constitute trade secrets for purposes of the Trade Secret and Freedom of Information Acts. No disclosure to others, either in the United States or abroad, or reproduction of any part of the information supplied is to be made, and no manufacture, sale, or use of any invention or discovery disclosed herein shall be made, except by written authorization of Premier Aviation Inc.

This notice will not operate to nullify or limit rights granted by contract. The data subject to this restriction is contained in all sheets and is disclosed to personnel of Premier Aviation Inc. for the purpose(s) of internal use and distribution only.

**COPYRIGHT NOTICE**

**Copyright 1993**

**PREMIER Aviation, Inc.**

**PREMIER AVIATION  
SPLIT DIMMER SUPPLY  
MAINTENANCE MANUAL  
DWG NO. 004-72000**

**TABLE OF CONTENTS**

- I. General Information**
  - 1-1 Physical and Electrical Specifications
  - 1-2 Operational Description
- II. Circuit Description and Theory of Operation**
  - 2-1 Internal Power Distribution  
Dimmer Regulator Control Circuit  
Regulator On Full Output Bypass Circuit
  - 2-2 5 Volt Dimmer Circuit  
On/Off Control Circuit
- III. Alignment and Test Procedures**
  - 3-1 Alignment Procedure
  - 3-3 Acceptance Test Procedure
- IV. Circuit Maintenance and Repair**
  - 4-1 Trouble Shooting & Repair Guide
  - 4-2 PCB Parts List
  - 4-4 PCB Layout - Fig. 1
  - 4-5 Schematic - Fig.2
  - 4-6 Assembly Parts List
  - 4-7 Split Dimmer Supply Assy. - Fig.3

**PREMIER AVIATION  
SPLIT DIMMER SUPPLY  
MAINTENANCE MANUAL  
DWG NO. 004-72000**

**I. GENERAL INFORMATION**

**PHYSICAL and ELECTRICAL SPECIFICATIONS**

<u>SPECIFICATION</u>	<u>CHARACTERISTIC</u>
<b>PHYSICAL:</b>	
Height:	1.70"
Width:	5.00" includes mounting base plate 3.73" measured at the top
Length:	5.25" not including aircraft connector
Weight:	1.34 pounds
Mounting:	Base Mounted with 4 Number 8 Mounting Holes
Temperature Range Environmental:	-20°F to +167°F Full Electrical Load -28.8°C to +75°C
<b>ELECTRICAL:</b>	
Input Supply Voltage:	27.5 Volts DC
Input Supply Current:	5 Amperes Maximum
Dimming Control Voltage:	0 Volts DC to Input Supply +0.5
Idle Current: ( Both Dimmers off )	100.0 Milli Amperes Maximum
Output Load Full Bright: 28 Volt Dimmer Max 5 Volt Dimmer Max	3.5 Amperes Continuous 5.0 Amperes Continuous
Maximum Load Dimmed Intermittent: ( Less than 10 milli seconds )	
28 Volt Dimmer 5 Volt Dimmer	5.0 Amperes 6.0 Amperes
Designed Load Level Continuous: 28 Volt Dimmer 5 Volt Dimmer	3.0 Amperes 4.5 Amperes
Control Input Specifications: Dimming Control Resistance	5kΩ to 10kΩ. Control input impedance > 100kΩ
On/Off Control	0 - 0.7VDC (Ground) for On Condition ( to sink 3.0mA ) Open Switch Contact = OFF

**PREMIER AVIATION  
SPLIT DIMMER SUPPLY  
MAINTENANCE MANUAL  
DWG NO. 004-72000**

**OPERATIONAL DESCRIPTION**

The Split Dimming Supply was designed to supply both 5 volt and 28 volt dimming voltages to appropriate lighting systems. Each dimming control input pin and on/off input pins can be connected to their own 5k $\Omega$  or 10k $\Omega$  control potentiometer wipers and on/off switches for independent operation. The dimming output voltages can be slaved for control pot tracking by connecting the two dimming control input pins to one 5k $\Omega$  or 10k $\Omega$  control pot wiper and by connecting both on/off control input pins to one switch.

**PREMIER AVIATION  
SPLIT DIMMER SUPPLY  
MAINTENANCE MANUAL  
DWG NO. 004-72000**

## **II. CIRCUIT DESCRIPTION AND THEORY OF OPERATION**

### **Internal Power Distribution:**

Aircraft power as 27.5VDC is filtered by the inductive capacitive network of L1, C10 and C16. This filtered power is applied to the plus/minus 15VDC supply hybrid regulator IC U6. Capacitors C6, C7, C2 and C17 filter the regulator output. The filtered 27.5VDC power also supplies switching power voltage for U4 and U5 regulators and biasing for operational amplifiers U1,U2 and the power switch circuits of Q2 and Q3. Un-filtered power is routed to the normally open contacts of relay K1 for use during regulator bypass. The regulated voltage of the plus and minus 15 volt IC, U6, supplies biasing for operational amplifiers U3 A and B and also to their offset/nulling resistor networks.

### **Dimmer Regulator Control Circuit:**

Dimming Control voltage, varied from 0 to 27.5 volts DC, for the 28 volt dimmer is applied across filter capacitor C15 and through input resistor R1 to the non-inverting input (pin 3) of U1A. U1A buffers the input control voltage to drive the resistive divider network of R2 and R3 and signal smoothing capacitor C20. This signal is the input control voltage divided by 5 and is buffered by U2B to supply a stable current source of the control error signal to the next two signal amplifiers. The output of U2B feeds the inverting input (pin 2) of U3A. The gain of U3A is unity and is determined by resistors R4 and R5. The network resistors of R6, R27, R28 and R29 form the null offset signal source for U3A. The control voltage output of U3A is applied to the regulator error voltage summing network of R7 and R8. The switching regulator U4 switches  $V_{in}$  through its' internal pass transistor and attempts to drive the error Amp input (pin 3) to 2.5 volts DC. The output voltage of the regulator is determined by a combination of the regulator output and the control voltage from U3A. As the output of U3A (pin 1) goes negative the output of the regulator must go more positive in order to satisfy the 2.5 volt requirement of its' pin 3. The ratio of the developed error signal is approximately 5 to 1. Capacitor C1 is used as the reference voltage bypass while C12 sets the operating switching frequency for U4. Capacitor C22 is for feedback stabilization and to reduce oscillations in the error amplifier. The low pass output filter consists of L2 and C18 which convert the 28 volt switching voltage into filtered DC. The core of L2 was selected to insure low core saturation during high current demands.

### **Regulator On Full Output Bypass Circuit:**

The output of U2B (pin 7), buffered control error signal, is passed through R13 and into the non-inverting input (pin 3) of U2A. The inverting input is biased by  $V_{in}$  and resistor network of R9, R10 and R11. Amplifier U2A is configured as an integrated comparator and outputs a voltage after the non-inverting input (pin 3) voltage exceeds the voltage at the inverting input (pin 2). This output is delayed and filtered by the action of C4, C5 and R12. Resistor R11 is used to set the switching level of the comparator and causes the output to turn on whenever the control voltage is at or near full 28 volts. The output of U2A (pin 1) is passed through R26 to the gate of Q1 and when the output voltage exceeds 1 volt Q1 turns on and energizes the coil of relay K1 allowing the unfiltered DC at the normally open contacts to be switched to the 28 volt dimming output. This action causes the regulator, U4, to shut down and rest whenever full brightness is required.

**PREMIER AVIATION  
SPLIT DIMMER SUPPLY  
MAINTENANCE MANUAL  
DWG NO. 004-72000**

**5 Volt Dimmer Circuit:**

Dimming control voltage, varied between 0 and 27.5 volts DC, from the dimming control potentiometer is applied across C14 through R19 to the non-inverting input (pin 5) of U1B. The output of U1B (pin 7) is applied across divider network R20 and R21 and filtered by C21 this effectively divides the control signal by 5. The control signal goes to the inverting input of (pin 6) U3B through R18. The gain of U3B is set by R18 and R15 to one half. Amplifier U3B is offset adjusted by the action of resistors R30, R31, R32 and R14. The output of U3B (pin 7) is applied to resistor R17 and to the Amp input (pin 3) of regulator U5. The rest of the circuit operates much the same as U4 as described in the paragraph on the regulator control circuit. The regulated output feedback is passed through R16 to be summed with the control voltage from U7 to develop the 2.5 volt DC error voltage at pin 3 of U5. Inductor L3 and capacitor C8 and C19 form the output filter network and convert the 27 volt pulses out of U5 into the smoothed DC dimming voltage. The function of zener diode D2 is to act as a short to ground if the regulated output were to exceed 6.2 volts DC as the result of a regulator failure. The act of D2 conducting will cause the output fuse F2 to open, thereby preventing the low voltage lights in the aircraft from being subjected to an over voltage condition.

**On/Off Control Circuit:**

On off control is provided by Q2 and Q3. Transistor Q2 operates the 28 volt dimmer circuit while Q3 operates the 5 volt dimmer. Open switch contacts to the on off control lines allow for Vin to bias the gates of Q2 and Q3. With Q2 and Q3 biased on Vin is dropped across zener diodes D4 and D3 and is felt at the Amp inputs (pin 3) of regulators U4 and U5 as 5.6 volts DC. The voltage at the amp inputs of the regulators will exceed the expected 2.5 volts at these points and will cause the regulators to be turned off. A ground on the gates of either Q2 or Q3 will turn off the transistor and remove the Vin biasing from the zener diodes and from the amp input pin of the respective regulator.

**PREMIER AVIATION  
SPLIT DIMMER SUPPLY  
MAINTENANCE MANUAL  
DWG NO. 004-72000**

**III. ALIGNMENT AND TEST PROCEDURE**

**ALIGNMENT PROCEDURE**

**EQUIPMENT REQUIRED:**

Digital Volt Meter ( Calibrated for reading DC volts.)  
Regulated Power Supply, 28 volts DC at 3 Amperes  
Split Dimmer Test Set #077-22000-01

**BENCH ALIGNMENT:**

1. Insure that R11, R30 and R27 are turned fully clockwise. This can be determined by a slight clicking sound produced whenever the pot is turned in this direction. Or by counting a minimum of ten full turns of the adjustment screw.
2. Connect the unit to be aligned to the tester. Insure all test set switches are in the OFF or LOW position and that the ADJUST knob is turned fully counter clockwise and in the off detente before connecting the 28 volt regulated supply to the tester.
3. Turn power on to the Test Set ( Regulated Power Supply Switch to ON ) and insure that the DC supply output is adjusted for 27.5 +-0.10 volts.
4. Place the 5 and 28 volt ON/OFF toggle switches in the ON or up position. Rotate the ADJUST knob clockwise until it is turned fully counter clockwise and just out of the Off detente.
5. Monitor the voltage between the 28 DIM test jack and GND with a digital volt meter. Adjust R27 counter clockwise until the meter reads 3.0 +- 0.10 volts.
6. Monitor the voltage between the 5 DIM test jack and GND with a digital voltmeter. Adjust R30 counter clockwise until the meter reads 1.10 +- 0.10 volts.
7. Turn the ADJUST knob fully clockwise. Connect the DVM between the 28 DIM test jack and GND and verify that the DVM reads somewhere between 18 and 22 volts.
8. Slowly turn R11 counter clockwise until the DVM reading jumps from the reading previously noted in step number 7 to more than 27 volts. (This will happen when K2 energizes.)
9. Return the ADJUST knob fully counter clockwise without engaging the off detente. Place the 5 LOAD switch in the HIGH position.
10. While monitoring between 5 DIM and GND test points adjust R30 for a reading of 1.10 +-0.10 volts. Turn the ADJUST knob fully clockwise and note the difference between the DVM reading and 4.50 volts.
11. Adjust R30 for a DVM reading of 4.50 plus or minus half the difference reading noted in step 10.

**PREMIER AVIATION  
SPLIT DIMMER SUPPLY  
MAINTENANCE MANUAL  
DWG NO. 004-72000**

12. Rotate the ADJUST knob fully counter clockwise without engaging the off detente. Place the 28 LOAD switch in the high position and monitor the 28 DIM test jack and GND with the DVM. Adjust R27 for 9.5  $\pm$  0.10 volts.
13. Turn the ADJUST knob clockwise till the DVM reads 19.0  $\pm$  0.10 volts. Use the DVM to verify that the 5 DIM test point reading is 3.10  $\pm$  0.20 volts. Place the 28 LOAD and 5 LOAD switches in the LOW (down) position.
14. While monitoring the 28 DIM test point slowly turn the ADJUST knob clockwise and note that the reading passes through 26  $\pm$  0.40 volts near the top of the ADJUST knob travel and then the reading jumps to a reading of 27 volts as K1 engages. If this fails to happen then turn R11 counter clockwise until the DVM reads 27 to 27.5 volts as a result of K1 engaging.
15. Turn the ADJUST knob counter clockwise until K1 de-energizes and the DVM reads around 26 volts. Verify that the 5 DIM test point reads between 4.2 and 4.5 volts.
16. Turn the ADJUST knob fully clockwise and verify K1 energizes and the 28 DIM test point reads 27 to 27.5 volts as a result of K1 engaging.
17. Turn the ADJUST knob counter clockwise until the DVM monitoring the 28 DIM reads 19 volts.
18. Place the 28 volt ON/OFF switch in the OFF position and verify that the DVM reads 0  $\pm$  0.10 volts.
19. Monitor the 5 DIM test point with the DVM and place the 5 volt ON/OFF switch in the OFF position and verify that the DVM reads 0  $\pm$  0.10 volts.
20. Rotate the ADJUST knob fully counter clockwise and in the off detente. Remove power from the test set. Alignment is completed.
21. Seal R11, R27 and R30 with Torque Seal to prevent movement to the adjustments that have been set.

**PREMIER AVIATION  
SPLIT DIMMER SUPPLY  
MAINTENANCE MANUAL  
DWG NO. 004-72000**

**ACCEPTANCE TEST PROCEDURE**

**EQUIPMENT REQUIRED:**

Digital Volt Meter ( Calibrated for reading DC volts.)  
Regulated Power Supply, 28 volts DC at 3 Amperes  
Split Dimmer Test Set 077-22000-01

**TEST PROCEDURE:**

1. Connect the unit to be tested to the Split Dimmer Test Set. Insure that all test set switches are in the OFF or LOW position and that the ADJUST knob is fully counter clockwise and in the off detente before connecting the 28 volt power supply to the test set.
2. Turn power on to the Test Set (Regulated Power Supply Switch to ON) and insure that the DC supply output is adjusted for 27.5  $\pm$ 0.10 volts.
3. Place the 5 and 28 volt ON/OFF toggle switches in the ON or up position. Rotate the ADJUST knob clockwise until it is turned just out of the Off detente.
4. Monitor the 28 DIM test jack with the DVM in relation to the GND test jack. Verify a reading of 9.50  $\pm$ 0.125 volts.
5. Move the DVM test probe to the 5 DIM test jack and verify a reading of 1.10  $\pm$  0.125 volts.
6. Turn the ADJUST knob fully clockwise and verify that the DVM now reads 4.5  $\pm$ 0.125 volts. Check the voltage at the 28 DIM test jack and verify a reading of more than 27 volts.
7. Slowly rotate the ADJUST knob counter clockwise until the DVM reading goes to less than 27 volts. The reading should be 26.25  $\pm$ 0.40 volts. The adjust knob travel should have been less that 1/4 turn when this happened.
8. Read the 5 DIM test jack and verify a reading of 4.20 to 4.50 volts.
9. Monitor the 28 DIM test jack and slowly rotate the ADJUST knob counter clockwise till the DVM reads 19.0  $\pm$ 0.10 volts. The 5 DIM test jack should read 3.10  $\pm$ 0.25 volts.
10. Place the 28 and 5 LOAD switches in the HIGH or up position. Verify that the readings at the 5 DIM and 28 DIM test jacks have not varied from the readings in step 9 by more than 0.150 volts.
11. Monitor the 5 DIM test jack with the DVM and place the 5 ON/OFF switch in the OFF (down) position. Verify that the DVM now reads 0  $\pm$  0.10 volts.
12. Monitor the 28 DIM test jack with the DVM and place the 28 ON/OFF switch in the OFF (down) position. Verify that the DVM now reads 0  $\pm$  0.10 volts.
13. Remove power from the test set. Acceptance test is completed.

**PREMIER AVIATION  
SPLIT DIMMER SUPPLY  
MAINTENANCE MANUAL  
DWG NO. 004-72000**

**IV. CIRCUIT MAINTENANCE AND REPAIR**

**TROUBLE SHOOTING & REPAIR GUIDE**

It should be noted that the following voltage readings may vary from one unit to another and are to be used only as a general guideline when diagnosing circuit problems. CCW readings are with the ADJUST knob turned fully counter clockwise without engaging the OFF detente, unless otherwise noted, while all CW readings are with the ADJUST knob fully clockwise.

**CONTROL AMPLIFIERS:**

Control voltage from the control pot will vary at P7 and P8 from a minimum of about 2.0 volts CCW to a maximum of the supply voltage of 27.5 volts CW. The voltage reading out of the input circuit of the 5 volt dimmer read at the junction of R20 and R21 will vary from close to 0 volts CCW to 4.5 volts CW. The 28 volt dimmer control amp voltage, read at pin 7 of U2 will vary from 0 volts CCW to 4.5 volts CW.

**VARIABLE CONTROL OFFSET AMPLIFIERS:**

The voltage readings at the output of the 28 volt Control Offset amplifier U3A pin 1 will vary from 3.6 volts CCW to 0 volts CW after R27 has been properly set. The output of the 5 volt Offset Amplifier U3 pin 7 will vary from 7.0 volts CCW to about 1.0 volts CW.

**REGULATOR FEEDBACK READINGS:**

An operating regulator U4 or U5 will maintain a reading of 2.5 volts at pin 3 when operating. When the ADJUST knob is fully CW and the Upper Limit detector has Engaged the K1 pin 3 of U4 will be forced to exceed 2.5 volts. This action will cause U4 to shut down.

**UPPER LIMIT DETECTOR:**

Comparator U2 pin 1 will be close to 0 volt ground when the ADJUST knob is CCW as the ADJUST knob approaches CW the voltage at pin 1 will jump to 24.0 volts.

**ON/OFF CONTROL CIRCUITS:**

With the ADJUST knob fully CCW and in the OFF detente Q2 and Q3 will be turned on allowing a zener limited voltage of 5.1 volts to be felt at pin 3 of both regulators U3 and U4 preventing them from operating. The /ON ground applied to the gate of Q2 and Q3 will cause them to turn off.

**PREMIER AVIATION  
SPLIT DIMMER SUPPLY  
MAINTENANCE MANUAL  
DWG NO. 004-72000**

**PCB PARTS LIST**

<u>Item</u>	<u>Quan.</u>	<u>Reference</u>	<u>Description</u>	<u>Part Number</u>
1	2	C3,C1	10ufd Tant.	P2065 (81F4069)
2	5	C2,C16,C17,C18,C19,C22	0.1ufd Cer.	CK068X104K
3	4	C4,C5,C20,C21	4.7ufd Elec.	P6263
4	2	C6,C7	100ufd Elec.	P6268
5	2	C9,C8	2200ufd Elec.	P6273
6	1	C10	470ufd Elec.	P6271
7	1	C11*	0.068ufd Cer.	P4429
8	1	C13	0.001ufd Cer.	CK05BX102M
9	2	C14,C15	1.0ufd Elec.	P931
10	1	C12	220pfd Cer.	CKO5BX221K
11	1	C23	0.47ufd Cer.	CK05BX474K
12	3	D1,D5,D6	Diode Rect.	1N4005
13	1	D2	Zener Diode 10.0V 1W	1N4740A
14	2	D4,D3	Zener Diode 5.6V 1W	1N4734A
15	1	F1	Pico Fuse 5A	251005
16	1	F2	Pico Fuse 7A	251007
17	1	K1	Relay DPDT	2BN-2A-126
18	1	L1	Inductor 50uH	025-22003-01
19	2	L2,L3	Inductor 200mH	025-22002-01
20	3	Q1,Q2,Q3	Hexfet Transistor	2N7000
21	1	R11	Multi-Turn Pot 10k	3296W-103ND
22	8	R1,R4,R5,R8,R13,R15, R19,R26	Res. MF 1/4W 10k	RLR07C1002FS
23	6	R2,R9,R18, R20,R22,R24	Res. MF 1/4W 5.11k	RN55H5111FS
24	3	R3,R16,R21	Res. MF 1/4W 1k	RLR07C1001FS
25	1	R6	Res. MF 1/4W 4.99k	RN55D4991F
26	2	R27,R30	Multi-Turn Pot 2k	3296W-202ND
27	5	R7,R10,R17,R23,R25	Res. MF 1/4W 2k	RLR07C2001FS
28	1	R12	Res. MF 1/4W 2.8M	RLR07C2804F
29	1	R14	Res. MF 1/4W 3.32k	RNC55H3321FS
30	3	R28,R29,R32	Res. MF 1/4W 4.02k	4.02KX
31	1	R33*	Res. MF 1/4W 5.62k	RNC55H5621FS
32	1	R31	Res. MF 1/4W 3.01k	RNC55H3011FS
33	3	U1,U2,U3	IC, Dual Op-Amp	LM158H
34	1	U4	IC, Switching Reg.	LH1605(HS7067)
35	1	U5	IC, Switching Reg.	LH1605
36	1	U6	Power Hybrid Supply	DIP241515DB
37	1	No Ref	Blank PCB	080-22014-05
38	2	No Ref	Torroid mount washer (Drilled to fit)	VTC1000312
39	7	No ref	1/8"d. 6-32 th. spacer	1560B
40	4	P1,P2,P3,P4	Turret 0.060"dia.	1533-2
41	4	P5,P6,P7,P8	Turret 0.035"dia.	1515-2
42	-	No Ref	Wire #18AWG	
43	-	No Ref	Wire #24AWG	

**PREMIER AVIATION  
SPLIT DIMMER SUPPLY  
MAINTENANCE MANUAL  
DWG NO. 004-72000**

<u>Item</u>	<u>Quan.</u>	<u>Reference</u>	<u>Description</u>	<u>Part Number</u>
44	4	L4,L5,L9, L10	Ferrite Bead	0013-0006-000
45	8	L6,L7,L8, L11,L12,L13,L14,L15	Ferrite Bead	264-3000-81

\* NOTE: Only use C11 and R33 if U4 is an HS7067. Otherwise leave the component positions open.

PREMIER AVIATION  
 SPLIT DIMMER SUPPLY  
 MAINTENANCE MANUAL  
 DWG NO. 004-72000

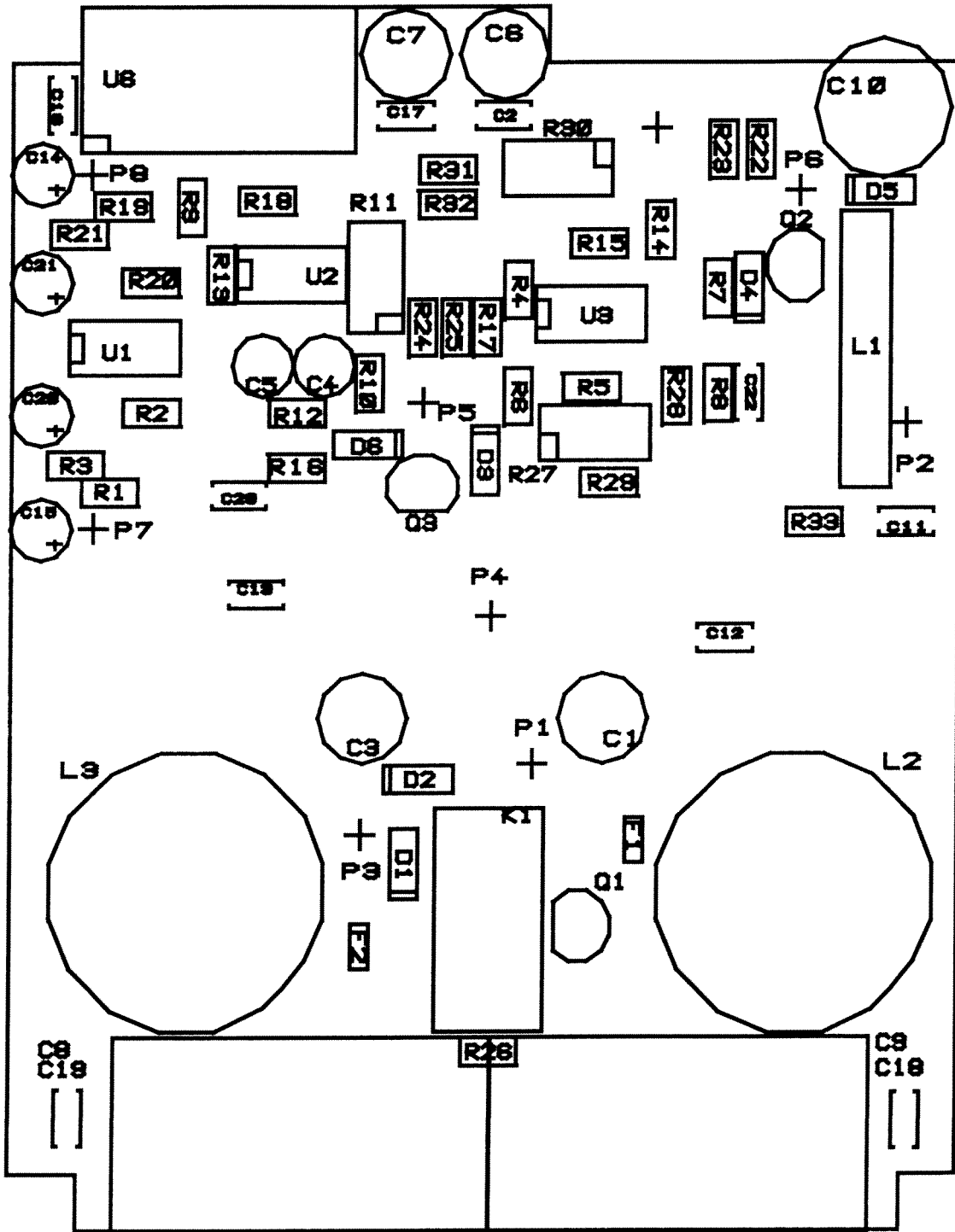
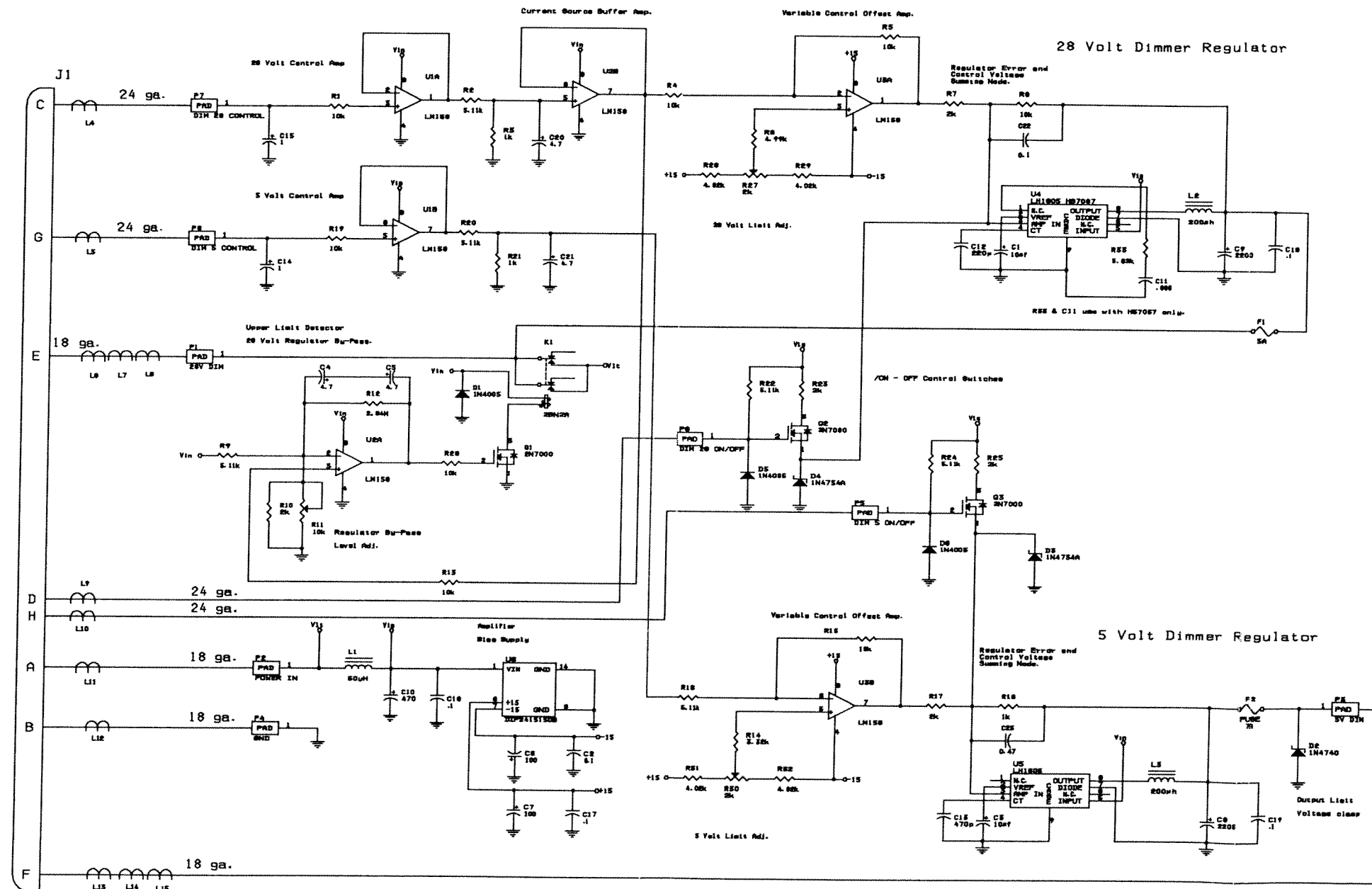

FIGURE 1: PCB LAYOUT

**PREMIER AVIATION  
SPLIT DIMMER SUPPLY  
MAINTENANCE MANUAL  
DWG NO. 004-72000**



**FIGURE 2: SCHEMATIC**

**PREMIER AVIATION  
SPLIT DIMMER SUPPLY  
MAINTENANCE MANUAL  
DWG NO. 004-72000**

**ASSEMBLY PARTS LIST**

<u>Item</u>	<u>Quan.</u>	<u>Reference</u>	<u>Description</u>	<u>Part Number</u>
		No Ref	Split Dimmer Complete	080-22014-01
1	1	No Ref	PCB assembled	080-22014-03
2	1	No Ref	Box Assembly	080-22014-19
3	1	No Ref	Heat Sink / Cover	080-22014-15
4	1	J1	Connector 10 pin	MS3112E12-10P
5	1	No Ref	Screw PCB mounting	MS35206-214
6	4	No Ref	Screw Torroid/PCB	MS24693-11
7	4	No Ref	Screw (Reg. Mount)	MS51957-30
8	4	No Ref	Lock Washer	MS35338-41
9	4	No Ref	Screw (Cover Plate)	MS51957-29B
10	4	No Ref	Lock Washer	MS5338-41
11	4	No Ref	Screw (Connector)	MS35206-213
12	1	No Ref	Nut Ring	FSU1201

Note: Pg. 4-7 (figure 3) to be added in revision A.

<input checked="" type="checkbox"/> ECO <input type="checkbox"/> ECR	NO. <b>4658</b>	EFF DATE OF CHG <b>07 DEC. 95</b>	REQUESTED BY ECR's 879, 887, 888, 903, 905	PREMIER	PAGE 1 OF 1
--	-----------------	--------------------------------------	--	---------	----------------

REASON FOR CHANGE PRODUCT IMPROVEMENT	DOCUMENTS AFFECTED 048-22000 004-72000 051-22000 106-25002 025-22004	SYSTEM MULTIPLE	MATL DISPOSITION	
		SERIAL NO EFF	REWORK	STORE
MARKED PRINTS ATTACHED YES <input type="checkbox"/> NO <input checked="" type="checkbox"/>			SCRAP	
			USE AS IS	

DISPOSITION/COMMENTS THIS ECO IS UNINCORPORATED.  
 048-22000 IS REV "-"  
 004-72000 IS REV "-"  
 051-22000 IS REV "-"  
 106-25002 IS REV "C"  
 025-22004 IS REV "-"

STC SH3762SW/ SH7744SW  
 STC SH8423SW/ SH8938SW

**DESCRIPTION**

048-22000 - REFERENCE ECR 879.

CHANGE ALL REFERENCES TO MS24693-205 SCREW TO MS24693-S205 SCREW IN P/L AND F/D.

004-72000 - REFERENCE ECR 887.

ADD FW5A1201S04 AS ALTERNATE P/N FOR ITEM 17 ON PG. 4-2.

051-22000 - REFERENCE ECR 888.

SHEET 3 ZONE 2D - CHANGE .90 DIA HOLE CALLOUT TO 1.00 DIA HOLE.

SHEET 3 ZONE 2B - CHANGE ARROW INDICATING "PIN 1 TOP SIDE" ON XFERJI TO POINT DOWN.

106-25002 - REFERENCE ECR 903.

SHEET 2 ZONE 2C - CHANGE -13 LABEL HORIZONTAL DIMENSION TO 3.00.  
 CHANGE -13 LABEL TO READ 106-25002-XX REV X.

025-22004 - REFERENCE ECR 905.

CHANGE ALL REFERENCES TO 843677310-A7 TO 2643002402 IN P/L AND F/D.

**COPY**

IMPACT		PROCUREMENT ACTION		PRIORITY		CHANGE CLASSIFICATION	
INTERCHANGEABILITY	YES <input checked="" type="checkbox"/> NO <input type="checkbox"/>	YES <input checked="" type="checkbox"/> NO <input type="checkbox"/>	1 <input type="checkbox"/>	2 <input type="checkbox"/>	3 <input checked="" type="checkbox"/>	<input checked="" type="checkbox"/> RECORD	
DRAWING CHANGE	<input type="checkbox"/>					<input type="checkbox"/> PMA MAJOR	<input type="checkbox"/> TSO MAJOR
SPECIFICATION	<input type="checkbox"/>					<input type="checkbox"/> PMA MINOR	<input type="checkbox"/> TSO MINOR
SPARES	<input type="checkbox"/>						
PREPARED BY	DATE	PROJECT ENG	DATE	QA	DATE	FAA SUBMITTAL	
P. VANOVER	12/5/95				12/7/95	YES	
CHECKED BY	DATE	MFG	DATE	PROD/SPRT	DATE	ENGRG APPR	DATE
Rich J. Reynolds	06 DEC 95					W. Hamaker	12/7/95

ECO  ECR

4658

<input checked="" type="checkbox"/> ECO <input type="checkbox"/> ECR	NO. 4771	EFF DATE OF CHG 19 JUNE 96	REQUESTED BY ECR'S 938, 939	PREMIER	PAGE 1 OF 2
--	----------	----------------------------	-----------------------------	---------	-------------

REASON FOR CHANGE PRODUCT UPDATE	DOCUMENTS AFFECTED 080-22014 004-72000 025-22005	SYSTEM SPLIT DIMMER, INDUCTOR	MATL DISPOSITION		
		SERIAL NO EFF	REWORK	STORE	IN MFG.
MARKED PRINTS ATTACHED YES <input type="checkbox"/> NO <input checked="" type="checkbox"/>			SCRAP		
			USE AS IS		

DISPOSITION/COMMENTS  
 THIS ECO IS INCORPORATED ON 080-22014 REV WAS "A", IS "B". STC SH8423SW  
 THIS ECO IS UNINCORPORATED ON 004-72000 REV IS "-".  
 THIS ECO IS UNINCORPORATED ON 025-22005 REV IS "-". INCORP PER ECO 0065

**DESCRIPTION**

080-22014

THIS ECO INCORPORATES ECO'S 4241, 4373, 4417, 4446, 4589 AND 4630 AS THEY PERTAIN TO 080-22014.

SHEET 1 -  
 CHANGED NOTES 1, 2 AND 3 TO READ -

- IDENTIFY PARTS PER PREMIER IDENTIFICATION AND MARKING PROCEDURES 115-12112. LOCATION, CHARACTER HEIGHT, AND PROCESS AS REQUIRED. MARK IN CONTRASTING COLOR.
- REMOVE ALL BURRS, BREAK ALL EDGES / CORNERS .015 MAX. EXCEPT AS NOTED.
- CHEM FILM (ALODINE) ALL ALUMINUM DETAIL PARTS PER 008-93003, AND PRIME WITH EPOXY PRIMER PER MIL-P-23377C, ZINC CHROMATE PRIMER PER MIL-TTP-1757, OR EQUIVALENT. THEN PAINT PER FED-STD-595 FLAT BLACK IMRON #37038.

P/L -  
 CHANGED MS24693-11 TO MS24693-S11  
 ADDED RTV5220 SEALANT, GE, QTY AR TO -03 COLUMN.

**COPY**

ECO 4771

ECR

IMPACT		PROCUREMENT ACTION		PRIORITY		CHANGE CLASSIFICATION	
INTERCHANGEABILITY	YES <input type="checkbox"/> NO <input checked="" type="checkbox"/>	YES <input checked="" type="checkbox"/> NO <input type="checkbox"/>	1 <input type="checkbox"/>	2 <input type="checkbox"/>	3 <input checked="" type="checkbox"/>	<input type="checkbox"/> RECORD	<input type="checkbox"/> PMA MAJOR <input type="checkbox"/> TSO MAJOR
DRAWING CHANGE	<input checked="" type="checkbox"/> <input type="checkbox"/>					<input type="checkbox"/> PMA MINOR <input type="checkbox"/> TSO MINOR	
SPECIFICATION	<input type="checkbox"/> <input checked="" type="checkbox"/>						
SPARES	<input type="checkbox"/> <input checked="" type="checkbox"/>						
PREPARED BY	DATE	PROJECT ENG	DATE	QA	DATE	FAA SUBMITTAL	
P. VANOVER	6/19/96	<i>[Signature]</i>		<i>[Signature]</i>	6/20/96	YES	
CHECKED BY	DATE	MFG	DATE	PROD SPRT	DATE	ENGRG APPR	DATE
<i>[Signature]</i>	6/19/96	<i>[Signature]</i>		<i>[Signature]</i>		<i>[Signature]</i>	6/19/96

080-22014

SHEET 4 - ZONE 7C:

ADDED ARROW THAT READS -  
BEAD RTV5220 AR AROUND ENTIRE SURFACE AFTER FINAL  
INSPECTION PRIOR TO CLOSING.

ZONE 7B:

CHANGED MS24693-11 CALLOUT TO MS24693-S11.

004-72000

PG 4-6 - CHANGE ITEM 6 MS24693-11 SCREW TO MS24693-S11  
ADD ITEM 13 - QTY AR, NO REF, SEALANT, RTV5220.

025-22005

ADD NOTE 3 TO READ -  
COIL VALUE WILL BE 250μH +35% -0%.

Re: 025-22005  
Incorp per ECO 6065

COPY

ECO 4771

ECR

ECR  
ECO 4771